

# **The Undergraduate Introductory Physics Textbook and the Future**

10 May 2012

Colin Zwiebel

AHS Capstone Disciplinary Deliverable

Franklin W. Olin College of Engineering

Advisor: Dr. Kenneth Hawes

Wellesley College

## **Preface: Course Correction**

The concept of this research project was to look at recent innovation and best practice in STEM undergraduate learning materials through an artifact: the textbook. I was determined to better understand practices within undergraduate textbooks that made them effective learning instruments. With the hope of investigating an aspect of the books that would be objective and comparable across different texts, I thought it would be wise to look at the printed features of STEM textbooks<sup>1</sup>, items such as in-margin definitions, chapter summaries, self-quiz problems, etc. My hypothesis was that over the course of the twentieth century, STEM education was becoming increasingly student oriented and that as evidence, I would find an increase in study features of the textbooks. Not far into my research, my plan was thrown in peril when I found a book by ex-editorial directory of McGraw-Hill Beverlee Jobrack (2011) which confirmed that I was correct about increases in textbook features, yet running the complete wrong course.

In textbook development, the primary [driving] factors were what the successful competition did, what would appeal to teachers, and how to design and label the work to highlight the appealing features. (Jobrack, p. xviii).

Textbooks were indeed including more study features and better labeling, but this was not a fruitful direction. Publishers focused on the design of their books because it was a good marketing move, not because these features had educational value. Even coming from her post as editorial director, Jobrack believed textbooks were moving in the wrong direction: “My products earned a host of awards for design, innovation, sales, and editorial excellence. They never earned any awards for effectiveness because to my knowledge awards for effectiveness do not exist,” (xviii). I saw no reason to investigate a facet of the textbook that was fundamentally misguided, and so I changed direction. It has been an

---

<sup>1</sup> I limited myself to undergraduate introductory physics textbooks.

interesting journey. Like William Herschel, who searched the 1781 night sky for double stars and found the planet Uranus instead (National Air and Space Museum, 2002), the unexpected path is often more exciting than the planned one.

## Introduction

Educational materials are an incredibly important aspect of undergraduate STEM education. Topics traditionally deemed complex can be easily understood given the right materials. Framed correctly, they are even exciting. Representing a manual of instruction for a discipline, textbooks are the predominant source material students' use in undergraduate education.

In contemporary times, access to educational materials has exploded. On-demand printing has opened doors for narrow-audience<sup>2</sup> and amateur textbooks; open-source texts and class materials such as MIT's OpenCourseWare are available to anyone with internet access. Furthermore, publishers are beginning to experiment with eBook formats and tablet devices, moving the text from the realm of static paper to dynamic media. Beyond educational materials, the past few years has seen the introduction of university supported introductory online courses such as Stanford's *Introduction to Machine Learning* course (Beckett, 2011).

These changes in access to materials and the types of materials utilized raise questions about the role of textbooks in higher education. What is the future shape of educational materials? Are textbooks still relevant?

But before considering questions of the future of educational materials and the textbook, I believe it is important to understand the development of textbooks over the previous century. Who are the stakeholders? What role do they play? What conditions create innovation in educational materials? This

---

<sup>2</sup> In 2010, over one-hundred-twenty-seven thousand self-published book were released directly by their authors (Trachtenberg, 2011).

paper is an investigation of these questions. To best answer these questions, I sought to understand educational materials around undergraduate introductory physics. Specifically, I used Robert Resnick and David Halliday's *Fundamentals of Physics* as a case study.

My conclusion: Great textbooks in higher education are the product of three things: field testing, a progressive vision, and timing. An academic (or a few collaborators) is not sufficient. The environment that produces great texts is one in which the academic has the opportunity to test their content. Finally, the text must catch the academic world at a time when instructors are amenable to innovation. It has been 50 years the last great physics textbook (Halliday and Resnick) was introduced. I believe educators and institutions are ready for a new wave of change. Big things are afoot.

## **Twentieth Century Physics – In Texts**

The American Physics Society recognizes four series of books as major introductory physics textbooks of the twentieth century (1999). Robert Millikan's *Mechanics, Molecular Physics and Heat* (published 1902) starts the APS' list, followed by A. Duff's *A Textbook of Physics* (published 1908). Collectively these texts saw thirty years of popularity, until Francis Sears released *The Principles of Physics* in 1944, and more importantly, the parallel series *University Physics* and *College Physics* in 1947 (both collaborations with Mark Zemansky, giving them the nickname Sears-and-Zemansky). However, none of these texts compare with introductory physics giant of the twentieth century: Halliday and Resnick.

In 1960 David Halliday and Robert Resnick released the gorilla introductory physics text of the twentieth century, *Physics for Students of Science and Engineering* which became the *Fundamentals of Physics* series (and which I shall refer to as H&R). Where Duff and Milikan's books published hundreds of thousands of copies of their book, H&R sold a million copies within its first decade (Holbrow, 1999, p. 54). Sears and Zemansky was commercially popular for a decade and a half while H&R remains the de facto introductory physics textbook today, fifty years past its first publication.

H&R brings up interesting questions. Why was H&R so successful and successful for so long? Is the commercial success warranted? How did the book change over its reign? What environment facilitated its creation? H&R is useful case study from which to build expectations for future, electronic physics educational materials.

### **Halliday and Resnick: Field Testing, Vision, and Timing**

Resnick's account of the creation of *Physics for Students of Scientists and Engineering* is very telling about the creation of higher education texts (Resnick, 1999). In 1955, Resnick signed a contract to John Wiley and Sons to write an engineering physics textbook -- a book for which Wiley did not have an offering. Resnick proposed the project to head of the physics department, David Halliday, and the two agreed to collaborate. An interesting thing happened a year later: On an academic visit to Renssaler Polytechnic Institute (RPI), Resnick was offered a position. Resnick refused, and continued to refuse, but RPI returned with more and more impressive offers. The force behind the offers was Wiley and Sons Chairman W. Bradford Wiley (Carvajal, 1998), an RPI trustee, who desired, for various reasons, to get Resnick away from the University of Pittsburg (which Resnick himself described as a "playboy school").

The move demonstrates the influence of the publisher as a stakeholder in the creation of educational materials. Whatever the motives behind Wiley's RPI bid for Resnick, the change of venue benefitted H&R. Resnick credits the increased academic rigor of the introductory physics students as making the text possible (Resnick, 1999).

Near completion of the text, Wiley and Sons sent the book to faculty at half-a-dozen colleges they hoped to sell the book upon publication (Resnick, 1999). All reviewers responded negatively, and Wiley planned to postpone publishing so Resnick and Halliday would alter the book. Several influential members of Wiley and Sons, Resnick attributes Solid-state Physicist and Wiley board member Bob Sprow, pushed to have the book published on schedule without revision. In 1960, under the title *Physics*

*for Students of Science and Engineering* Robert Resnick and David Halliday published the textbook the American Physics Society would call “the most outstanding introductory physics text of the twentieth century” (RPI).

Three environmental conditions emerge from Resnick: field testing, a progressive vision, and timing. Resnick credits his teaching experience at RPI as the key factor in producing the book. Shortly after moving to RPI, Resnick and Halliday restructured the introductory four-semester physics course, creating new educational materials (Resnick, 1999). Testing and feedback Resnick received teaching this course went into H&R. In contrast, Resnick did not benefit from the review process Wiley and Sons subjected the book to (and which might have dismantled their inclusion of modern physics).<sup>3</sup>

Resnick and Halliday had a strong vision for the inclusion of modern physics in their textbook, a component of the second contributor to great texts: progressive vision. Entirely unheard of before, Resnick and Halliday peppered their explanation of physics topics with modern physics (Resnick, 1999). Ford and Zemansky had largely avoided modern physics in their coverage. Atomic physics did not appear in Ford and Zemansky until the last 36 pages of the book (Holbrow, 1999, p. 53). Resnik and Halliday’s decision to weave modern physics throughout the text—or include it all, considering its place in physics education—was an act of vision. Including modern physics required cutting a significant number of traditional topics. “simple machines, surface tension, viscosity, calorimetry, change of state, humidity, pumps, practical engines, musical scales, architectural acoustics, electrochemistry, thermoelectricity, motors...” and dozen more topics were omitted (Holbrow, 1999). Furthermore, H&R demanded understanding of advanced math, frequently using vector calculus.

---

<sup>3</sup> The failure of review processes is evident elsewhere. Beverlee Jobrack and Richard Feynman both include committee review processes in their explanation of the failings of educational materials (Jobrack, 2011; Feynman, 1985).

Finally, Resnick was in the right place at the right time. Wiley did not have a comparable physics text at the time. Upon completion, H&R was not sold as an alternative physics text, but as Wiley and Son's primary offering. H&R was completed more than a decade after Ford and Zemansky in a period of time when modern physics had not found its proper place in physics education. Finally, three years before H&R was released, Russian researchers launched Sputnik, spurring great concern over the quality of science education in the United States—the perfect impetus to reconsider the structure of introductory physics and select a new textbook.

### **H&R Over the Years and the Force Concept Inventory**

Over the course of H&R's fifty-two year publishing streak, the book has seen nine editions. In 2002 the American Physics Society acknowledged the text, naming H&R the "most outstanding physics text of the 20th century." (Rensselaer, 2005, Robert Resnick). But what has H&R done to maintain its position on top? Is its continued success warranted?

In 1982 John Clement released research showing that students' knowledge of mechanics –and concepts used to understand mechanics— did not extend to their physical understanding of the world (Stewart, 2006). Clements found erroneous “conceptual primitives” that students brought into introductory physics courses. Clements research showed that upon completion of the course, many students maintained the same misconceptions they started with. One such common misunderstanding is that of force and acceleration. Clement showed students often misinterpret force and motion, making the assumption that motion implies the presence of a force. This flawed understanding contradicts Newton's first and second laws of motion. In response, several mechanics inventories have been developed to investigate misunderstanding of mechanics: Halloun and Hestenes' 1984 *Mechanics Diagnostic Test* (Halloun and Hestenes, 1985) and most recently, Hestenes, Wells, and Swackhamer's

*Force Concept Inventory* (Hestenes, Wells, and Swackhamer, 1992). Since the release of the MDT and FCI, significant effort has gone into finding effective practices for teaching mechanics (Hestenes and Halloun estimate ten-thousand student have taken the *Force Concept Inventory*).

The third edition of H&R was released in 1988 and seventh edition was released in 2005. This time period spans academic interest in the *Force Concept Inventory* and mechanics education. Halliday, Resnick (and new collaborator, Jearl Walker) should have been familiar with Clement's, Hestenes', and Halloun's research. So then, how did H&R change over these seventeen-years and four editions in response? Stewart investigated the relevant sections of H&R systematically, looking at readability calculations and metrics such as the quantity and size of diagrams (Stewart, 2006). The results question H&R's contribution to physics education since its introduction fifty years ago.

Within readability, Stewart looked at three different measure to measure ease of understanding. The first class investigated are readability indexes which gauge difficulty based on the distribution of characters, syllabi, words, and sentences. The main test within this group, the Flesch-Kincaid Readability Formula, was developed to assess Navy training manuals—technical documents. Flesch-Kincaid make the assumption that the number of syllables in each word is an indication of difficulty of the word, and therefore, difficulty of the text. Flesch-Kincaid also takes into account the number of words per sentence. Two other metrics, the Gunning "FOG" Index and the SMOG Grading Index, are also based on syllable count and words per sentence, but ignore words with fewer than three syllables. In addition to these metrics, Stewart looked at the Coleman-Liau Index and the Automated Readability Index, which are based on characters per word, rather than syllables per word.

Stewart's results show that H&R third edition is more readable than the seventh edition (Figure 1, Stewart, 2006). Only in comparing the "normal" representation of H&R3 and H&R7 on the Coleman-Liau Index did the seventh edition improve in readability (which is likely meaningless considering the



“normal” representations includes all equations written out in the TeX language). The seventh edition received a Gunning “Fog” Index of 12.1, which is deemed too difficult for general comprehension (H&R3 received an 11, below the 12 score cutoff). Nonetheless, on other scales the text itself is not terribly challenging. Flesh-Kincaid define 60-70 as the average range of English documents. All test of H&R3 and H&R7 fall within this range.

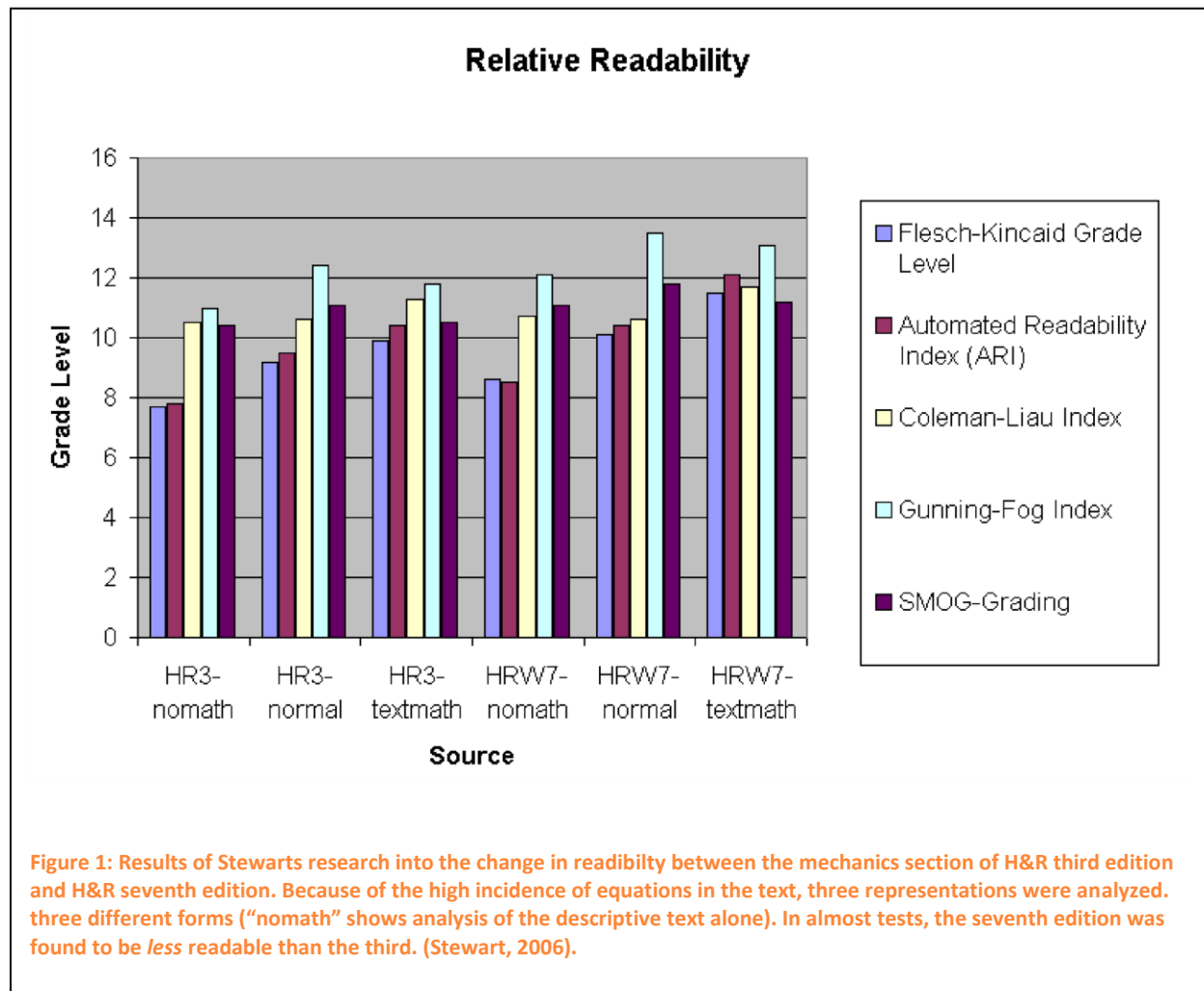

The rest of Stewart's research look at Lexical Analysis, references to other sections, and quantity and area of equations of figures. Stewart calculated David Hayes' LEX statistics on the mechanics sections of H&R (Stewart, 2006, p. 18). LEX is a cumulative distribution function statistic that measures the extent

to which a text is made up of common English words (using newspapers as a baseline). Cumulative distributions for several types of writing are shown in Figure 2. Here too, H&R3 has a lower LEX score than H&R7, suggesting better ease of comprehension. H&R3 received a full-text LEX statistic of -5.31; H&R7, -2.1. For comparison, articles from *The New England Journal of Medicine* in 1990 had a high complexity of 33.3, while *National Geographic* articles from 1984 had a modest -0.6 complexity, and *Sports Illustrated* articles from 1994 scored -10.3. Comparison across media is difficult because of media type greatly affects word choice. However, the comparison across version of H&R is valid. With further editions, the text increases in complexity in the mechanics section.

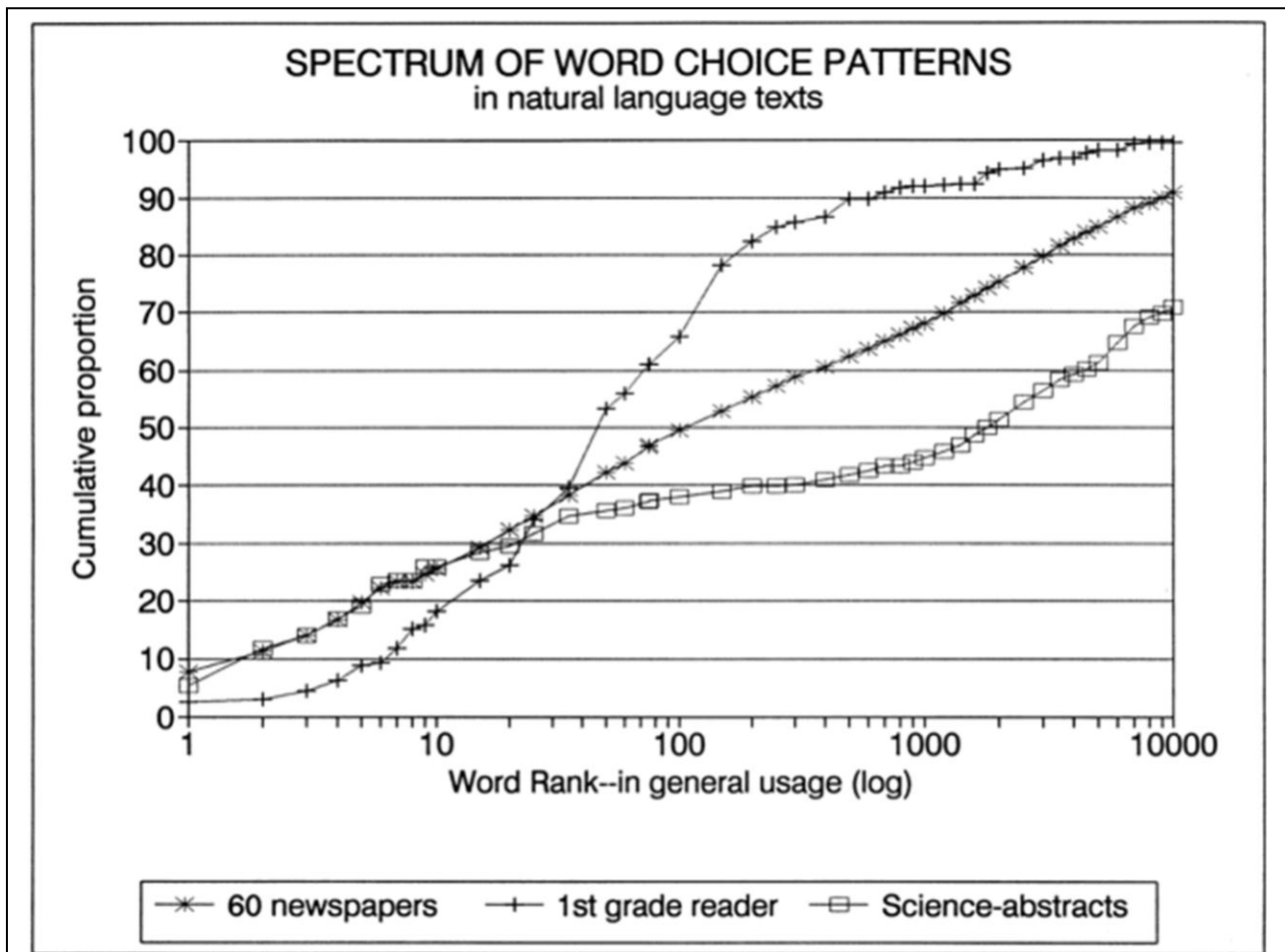
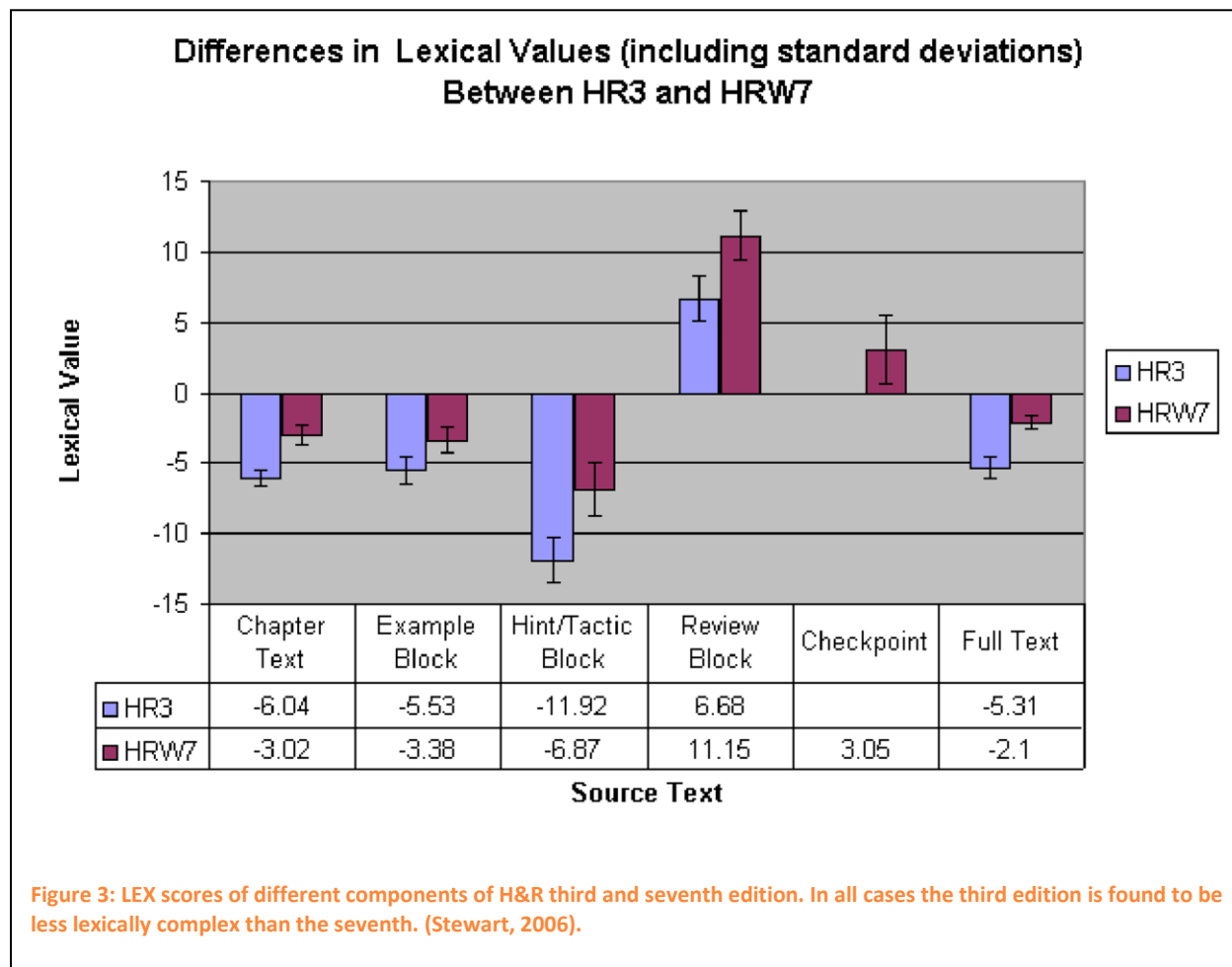

Figure 2: Cumulative distribution of words in newspapers, 1st grade basal readers, and science abstracts (as compared to general usage in English language newspapers). This distribution is the basis for the LEX statistic. By the 100<sup>th</sup> most common word in English language, the majority of the text of 1<sup>st</sup> grade basal readers is accounted for. In comparison, only by the 1100<sup>th</sup> most common English word are half the words in the science-abstracts accounted for (science abstracts taken from the journal Nature). (credit White, 2003)



Finally, Stewart looked at the number and integration of text references in the two editions of *Fundamentals of Physics*. H&R3 references chapters three times more often than H&R7 (Stewart, 2006, p. 26) and alluded to intriguing, advanced topics past chapter twelve (H&R7 made no references to chapters past eleven). H&R3 also made references example problems three times more than H&R7. H&R3 references twenty-one outside sources for further reading while H&R7 provides only two such references. All these results show H&R3 as a more integrated, self-referencing text.

Student conceptual understanding of mechanics has been of academic interest and widely tested with the *Force Concept Inventory*. Since the introduction of the FCI in 1992, the mechanics sections of *Fundamentals of Physics* has decreased in ease of understanding in two different types of metrics, and decreased in number of references. It seems unlikely that poor student understanding of force concepts points to a need for a more complicated explanation of physics. To the credit of H&R7, the seventh edition includes more thorough derivation of mechanics topics and twice the number of equations as H&R3, contributing at least partially to the decreased ease of understanding. Nonetheless, the direction H&R moved between the third and seventh edition suggests the continued publication of the textbook is not advancing physics education.

### **Unstable Ground in Publishing**

2011 was a pivotal year for the publishing industry. In February, Borders, the second largest (Spector, 2011) bookseller in the United States and mammoth multi-national corporation, filed for chapter 11 bankruptcy and began liquidating 226 stores (Ross, 2011). Unable to find a buyer Borders extended the liquidation to their remaining 399 stores and by September the last retail stores had closed their doors (Associated Press, 2011).

Long discussed, in 2011 the eBook finally appeared to make inroads on the publishing market. In a September press release, Amazon introduced a \$79 model of its Kindle ebook reader (Gilbert, 2011). "Apple Reinvents Textbooks with iBooks 2" (Apple Computer, 2012) is the title of press release Apple Computer published on in January of 2012. Apple's reinvented iPad textbook promised to be "an entirely new kind of textbook that's dynamic, engaging, and truly interactive."

Certainly, the future of physics educational materials will be interactive, but I do not believe it will be the ebook. The media world certainly looks uncertain for publishers, but the pressure started years before the iPad. The internet has been a major challenge for publishers. According to Jeff Shelstad, ex-

VP Editorial Director at Pearson, "The internet has caused so much disruption in the distribution [of textbooks] that there are so many used books and international books and pirated copies out there that after about two years, publishers have to bring out new editions in order to capture revenue again" (Snyder, 2008). *Fundamentals of Physics* validates this sentiment. Publisher Wiley and Sons released the eighth edition in 2008<sup>4</sup> only to release a ninth edition three years later in 2011<sup>5</sup>. If you include the eighth extended edition and ninth extended edition which Wiley also released over this time, that comes to four versions of the book over a three year period.

Textbook publishers have been hesitant with ebooks. *Fundamentals of Physics* only became available in ebook format with the eight edition (released 2008). Even then, Wiley released the book in a proprietary format that was incompatible with ebook standards such as ePub, arguably a piracy prevention move. Resistance to ebooks is not an outright hesitation against all things digital. Rather, educational publishers appear to have a different aim. Wiley and Sons has pushed toward an entirely new education product they call "WileyPlus." Essentially packaged physics course curriculum, WileyPlus *Fundamentals of Physics*, is an online education product that includes the textbook, interactive content, and course work. The cost to the student for *Fundamentals of Physics* WileyPlus? One-hundred-six dollars for the minimum package – which does not include the printed book or even a kindle version of the book.<sup>6</sup>

---

<sup>4</sup> [http://www.worldcat.org/title/fundamentals-of-physics/oclc/228783046?referer=brief\\_results](http://www.worldcat.org/title/fundamentals-of-physics/oclc/228783046?referer=brief_results)

<sup>5</sup> [http://www.worldcat.org/title/halliday-resnick-fundamentals-of-physics/oclc/685179670&referer=brief\\_results](http://www.worldcat.org/title/halliday-resnick-fundamentals-of-physics/oclc/685179670&referer=brief_results)

<sup>6</sup> <http://search.barnesandnoble.com/Fundamentals-of-Physics-WileyPLUS-Edition/David-Halliday/e/9780470909751>.

Ironically Wiley Canada mentions cost as one of the benefits of eLearning:

"In the science and technical fields, students spend an estimated \$100 for textbooks per one-semester course. Assuming that the average student completes 10 courses per academic year, the total average amount spent on textbooks to complete an undergraduate honours degree is \$4000. This figure is comparable to a full extra year's tuition." (Curtin, 2005)

Ironically, WileyPlus *Fundamentals of Physics* costs \$109; No cost benefit to the student and in fact a cost hike if the printed book is included.

In a traditional course, students own their texts and can use them as reference material. Is this still the case if students use online course products? In the case of WileyPlus, the answer is mixed. During the course, students read individual pages through Wiley's courseware. Students may print pages one at a time (Curtin, 2005). Even if students could download text pages, they would have to do so one at a time -- a full ebook of the text is not available.

From Wiley and Sons' perspective, promoting an electronic courseware version of *Fundamentals of Physics* removes many of their costs. Piracy is not possible with the courseware model – the product is a service which requires enrollment under a professor authorized by Wiley. Access is limited to the period of the course and material is not transferred to students' machines. As a bonus, by eliminating the book component of the textbook, an estimated third of the cost of each text disappears. Figures from the National Association of College Bookstores breaks down the sticker price of paper textbooks:

- 64.8% - Publisher
- 22.4% - College Store
- 11.6% - Author (royalties, pre-tax)
- 1.2% - Freight shipping

(AUM Bookstore).

## **Beyond Superficial Processing**

Feynman (1985) lodges a complaint against the popular university introductory physics book he was given to teach from while on leave at the Brazilian Center for Physics Research. In a presentation Feynman claimed the entire book was memorization. Feynman proceeded to pick and read a section of the book at random: "Triboluminescence. Triboluminescence is the light emitted when crystals are crushed." Feynman's comment: "have you got science? No! You have only told what a word means in terms of other words. You haven't told anything about nature-what crystals produce light when you crush them, why they produce light." Feynman's alternative: "if, instead, you were to write, 'When you take a lump of sugar and crush it with a pair of pliers in the dark, you can see a bluish flash. Some other

crystals do that too. Nobody knows why. The phenomenon is called "triboluminescence." Then someone will go home and try it." (Feynman, 1985, p. 217).

Feynman promotes text which inspires informal experimentation. The thinking process and activity that the textbook facilitates may be as important if not more important than the content covered in the text. In a 1990 study, Ferguson-Hessler and de Jong investigated the differences in study process between high achieving students and merely average students. They found that "poor" performers and "good" performers were equally active when reading the text, but that "bad" students performed nearly twice as many superficial study actions as "good" students (Fergusson-Hessler & de Jong, 1990). "Superficial" study processes involve limited processing, compared to the other two types of processes Ferguson-Hessler and de Jong considered: integrating and connecting.

### Three Categories of Study Processes

1. superficial processing (reading text, comparing symbols in text and figure)
2. integrating (bringing structure into new knowledge)
3. connecting (relating new knowledge to previous knowledge)

The study suggests that study tasks such as organizing content into new structures, manipulating equations, and visualizing relationships, increases retention. It stands to reason that content presented in such a way that promotes integrating and connecting processes would be more effective.

"instructional measures aimed at stimulating specific, deep study processes (e.g., explicating, relating, and confronting) might encourage some poor students to change their learning habits" (Ferguson-Hessler & de Jong, 1990).

The uncreative solution is to teach study skills -- an attempt at teaching students to fish. Indeed, most texts contain a "how to use this text" section. The SQ3R method taught at many universities is such an

attempt to teach students to extend beyond superficial processing tasks when studying. However, no amount of conscious effort can make up for uninspiring content. All students are capable of integrative study actions. If text was framed differently, it could tap into natural integrative tendencies. This is Feynman's solution: create text that excites readers to think about and perform informal experiments, so they don't have focus on turning over uninteresting material in their head.

## Conclusion and Beyond

What will the next great undergraduate introductory physics material look like? The possibilities are wide open. Is the textbook relevant? In other domains, certainly. As introductory learning material? Not in its current, static form. Stanford, MIT, and Harvard are on-board with online courseware. Even traditional publisher Wiley and Sons has a collection of such courseware available for purchase.

What environment will induce the production of a great introductory physics giant? Or similarly, what conditions should authors of such materials seek? Four years of in-class field testing at RPI was essential to the creation of *Fundamentals of Physics*. The next giant will require field testing. As for the two other factors, the visionary and timing, I still believe envelope-pushing educational materials are the product of a very limited number of academicians who share a common vision. The committee review process has certainly not benefited secondary education (as Beverlee, 2011 states very strongly). Timing looks very ripe. Only in 2011 did leading universities promote online courseware as a viable model for education (Beckett, 2011). With the next version of Windows moving to a touch interface, tablets (already quite commonplace) will become ubiquitous. No doubt publishing will be affected.

In closing I would like to leave you with three non-traditional educational material concepts. I hope the future will see a sea change instead of the same old textbooks on tablets instead of paper. The first is a real paper textbook written by Daniel P. Friedman. *The Little Schemer* is an introduction to the Scheme



programming language which departs entirely from the expository, taxonomic, definitional format of most textbooks. Friedman's book is entirely written in inquiry format as shown in Figure 4.

Is it true that this is an atom?  
atom<sup>1</sup>

Yes,  
because atom is a string of characters  
beginning with the letter a.

<sup>1</sup> L, S: (quote atom) or 'atom'  
"L" and "S" are described in the preface.

Is it true that this is an atom?  
turkey

Yes,  
because turkey is a string of characters  
beginning with a letter.

Is it true that this is an atom?  
1492

Yes,  
because 1492 is a string of digits.

Is it true that this is an atom?  
u

Yes,  
because u is a string of one character,  
which is a letter.

Is it true that this is an atom?  
\*abc\$

Yes,  
because \*abc\$ is a string of characters  
beginning with a letter or special character  
other than a left "(" or right ")"  
parenthesis.

Is it true that this is a list?  
(atom)<sup>1</sup>

Yes,  
because (atom) is an atom enclosed by  
parentheses.

<sup>1</sup> L, S: (quote (atom)) or '(atom)

Is it true that this is a list?  
(atom turkey or)

Yes,  
because it is a collection of atoms enclosed  
by parentheses.

Is it true that this is a list?  
(atom turkey) or

No,  
because these are actually two  
S-expressions not enclosed by parentheses.  
The first one is a list containing two  
atoms, and the second one is an atom.

Is it true that this is a list?  
((atom turkey) or)

Yes,  
because the two S-expressions are now  
enclosed by parentheses.

Is it true that this is an S-expression?  
xyz

Yes,  
because all atoms are S-expressions.

Is it true that this is an S-expression?  
(x y z)

Yes,  
because it is a list.

Is it true that this is an S-expression?  
((x y) z)

Yes,  
because all lists are S-expressions.

Is it true that this is a list?  
(how are you doing so far)

Yes,  
because it is a collection of S-expressions  
enclosed by parentheses.

How many S-expressions are in the list  
(how are you doing so far)  
and what are they?

Six,  
how, are, you, doing, so, and far.

Is it true that this is a list?  
(((how are) ((you) (doing so)) far)

Yes,  
because it is a collection of S-expressions  
enclosed by parentheses.

How many S-expressions are in the list  
(((how are) ((you) (doing so)) far)  
and what are they?

Three,  
((how are), ((you) (doing so)), and far.

Is it true that this is a list?  
( )

Yes,  
because it contains zero S-expressions  
enclosed by parentheses. This special  
S-expression is called the null (or empty)  
list.

Is it true that this is an atom?  
( )

No,  
because ( ) is just a list.

Is it true that this is a list?  
(() () ())

Yes,  
because it is a collection of S-expressions  
enclosed by parentheses.

What is the car of l  
where l is the argument  
(a b c)

a,  
because a is the first atom of this list.

What is the car of l  
where  
l is ((a b c) x y z)

(a b c),  
because (a b c) is the first S-expression of  
this non-empty list.

What is the car of l  
where l is hotdog

No answer.  
You cannot ask for the car of an atom.

What is the car of l  
where l is ( )

No answer.<sup>1</sup>  
You cannot ask for the car of the empty  
list.

<sup>1</sup> L: nil

**The Law of Car**  
The primitive car is defined  
only for non-empty lists.

Figure 4: The beginning 3 pages of Friedman's *The Little Schemer*. Friedman helps the learner invent the concepts of scheme, only providing a formal definition after working through an inquiry discovery process (Friedman, 1996).

The next is Bret Victor's concept for a basic circuits learning environment. Victor's conviction is that people need to have tangible feedback in their tools. He demonstrates the importance of Ubiquitous Visualization as well as in-context manipulation. His circuits simulation environment shows voltage and current at all points along the circuit and allows the user to slide time backwards and forwards, watching the device relationships create systematic behavior. The emphasis is learning through experimentation. Particularly for physics phenomena that is dangerous or prohibitively expensive, high quality, learning-oriented simulations would greatly improve student interest and understanding.

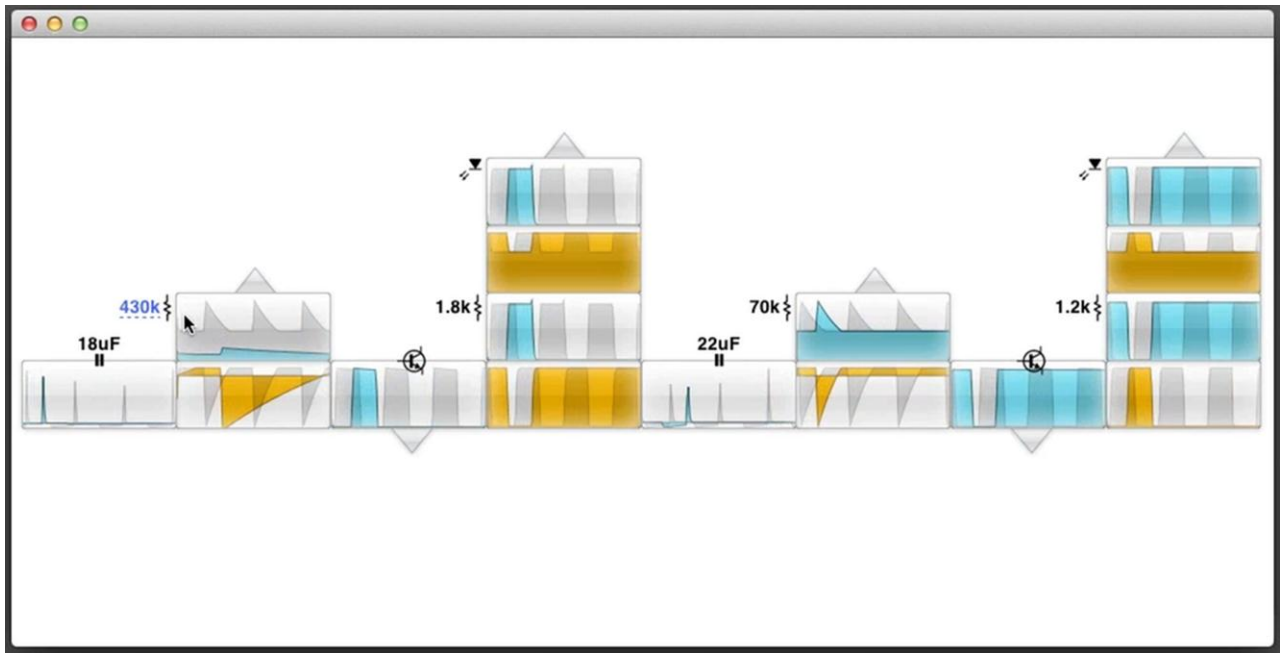
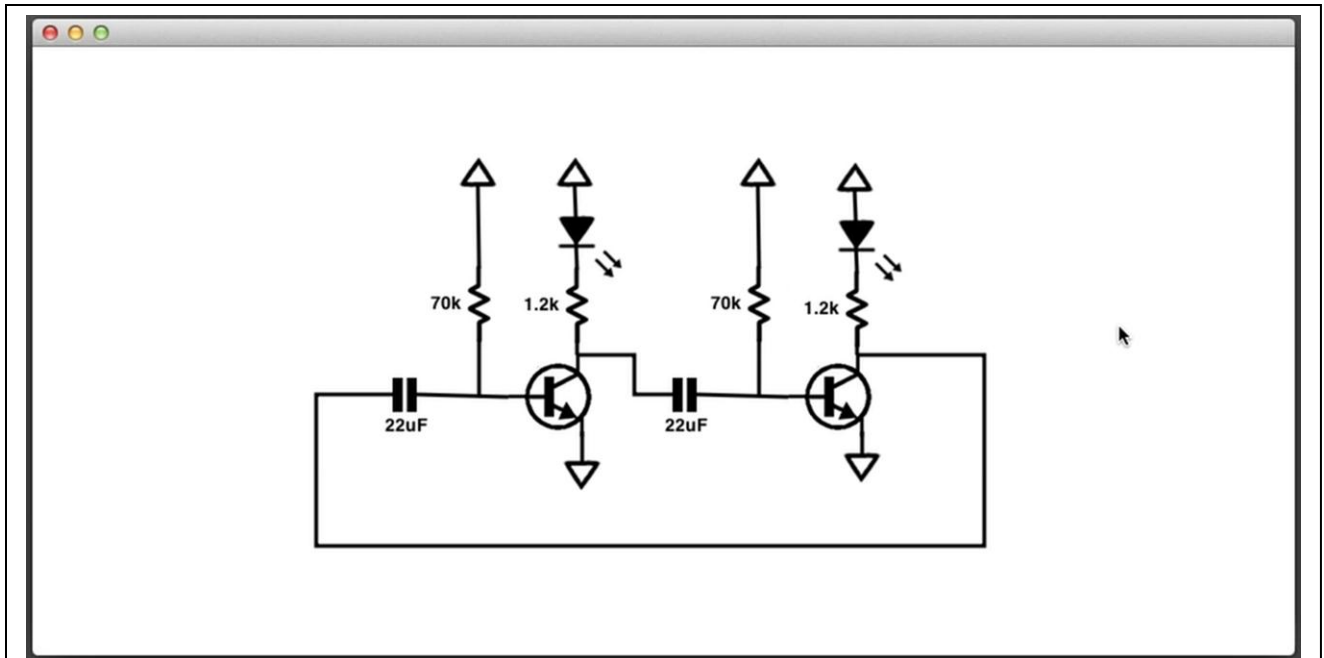

Figure 5: Bret Victor's circuit simulation concept. Victor emphasizes ubiquitous visualization and in-context manipulation. Please watch <http://vimeo.com/23839605> and <http://vimeo.com/36579366> to better understand Victor's interface.

Finally, I leave you with a screenshot of the NotaBene software project. NotaBene turns course reading into an in-context, collaborative activity by allowing students to have a discussion about material in the margin of the book (Figure 6, Zyto, Karger, Ackerman, and Mahon, 2012).

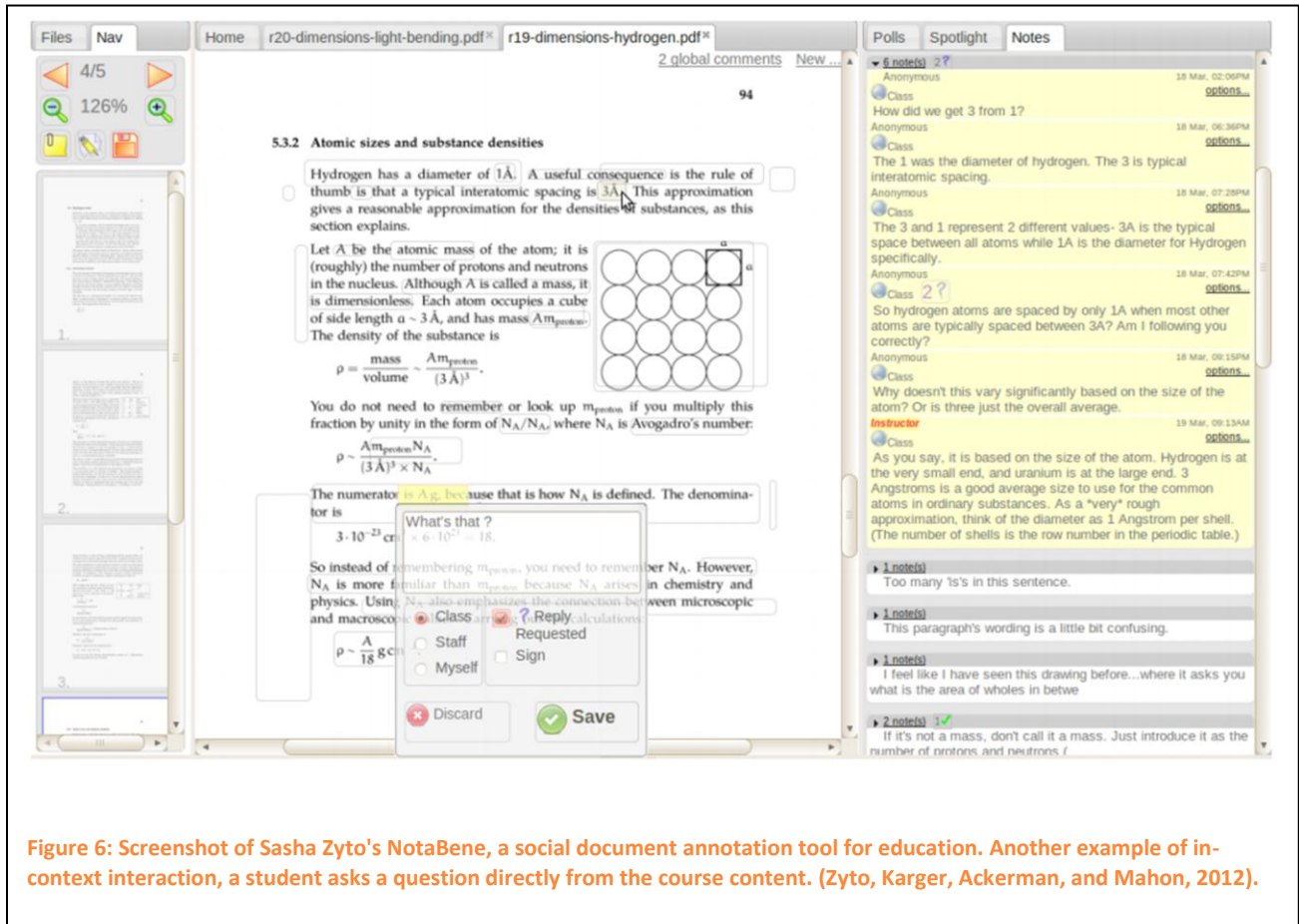

Figure 6: Screenshot of Sasha Zyto's NotaBene, a social document annotation tool for education. Another example of in-context interaction, a student asks a question directly from the course content. (Zyto, Karger, Ackerman, and Mahon, 2012).

There are so many options available to create interactive materials that cause student to examine physics through integrating and connecting thought processes, *please*, let us not simply transplant the textbook into the electronic device!

## Works Cited

Apple Computer. (2012). Apple Reinvents Textbooks with iBooks 2 for iPad [press release]. Retrieved

from: <http://www.apple.com/pr/library/2012/01/19Apple-Reinvents-Textbooks-with-iBooks-2-for-iPad.html>

Apple Computer. Volume Purchase Program – Frequently Asked Questions. Retrieved from:

<http://www.apple.com/education/volume-purchase-program/faq.html>.

Associated Press. (2011). Borders' Ann Arbor flagship store closes doors. Bloomberg Businessweek.

Retrieved from: <http://www.businessweek.com/ap/financialnews/D9PN9ID03.htm>

AUM Bookstore. Why do my textbooks cost so much? Retrieved from: [http://www.aum.edu/campus-](http://www.aum.edu/campus-life/aum-bookstore/why-do-my-textbooks-cost-so-much)

[life/aum-bookstore/why-do-my-textbooks-cost-so-much](http://www.aum.edu/campus-life/aum-bookstore/why-do-my-textbooks-cost-so-much)

Beckett, J. (2011, August 16). Free computer science courses, new teaching technology reinvents online education. Stanford University News. Retrieved from:

<http://news.stanford.edu/news/2011/august/online-computer-science-081611.html>

Carvajal, D. (1998). W. Bradford Wiley, 87, Independent Publisher. The New York Times. Retrieved from:

<http://www.nytimes.com/1998/02/05/business/w-bradford-wiley-87-independent-publisher.html>

Curtin, Luke. 2005. The Benefits of eLearning. Retrieved from

[http://www.wiley.com/legacy/products/worldwide/canada/wileyplus/online\\_learning.html](http://www.wiley.com/legacy/products/worldwide/canada/wileyplus/online_learning.html)

Feynman, R. P., Leighton, R., & Hutchings, E. (1985). "Surely you're joking, Mr. Feynman!": Adventures of a curious character. New York: W.W. Norton.

Ferguson-Hessler, M., & de, J. T. (1990, March 1). Studying Physics Texts: Differences in Study Processes Between Good and Poor Performers. *Cognition and Instruction*, 7, 1, 41-54.

Friedman, D. P., Felleisen, M., & Friedman, D. P. (1996). *The little Schemer*. Cambridge Mass: MIT Press.

Gilbert, J. (2011). Amazon Tablet Announcement (LIVE BLOG): Kindle Fire, Release Date, Price To Come? *Huffington Post*. Retrieved from: [http://www.huffingtonpost.com/2011/09/28/amazon-tablet-announcement-live-blog-kindle-fire\\_n\\_984780.html#9\\_amazon-announces-79-kindle](http://www.huffingtonpost.com/2011/09/28/amazon-tablet-announcement-live-blog-kindle-fire_n_984780.html#9_amazon-announces-79-kindle)

Government Accountability Office, Washington, DC. (2005). *College Textbooks: Enhanced Offerings Appear to Drive Recent Price Increases. Report to Congressional Requesters. GAO 05-806*. US Government Accountability Office. 441 G Street NW, Washington, DC 20548. Tel: 202-512-6000; Web site: <http://www.gao.gov>.

Halloun, I. A. & Hestenes D. (1985). The Initial Knowledge State of College Physics Students. *American Journal of Physics*, 53(11), 1043.

Hestenes, D., Wells, M., & Swackhamer, G. (1992, January 1). Force concept inventory. *The Physics Teacher*: 30, 3.

Holbrow, C. H. (January 01, 1999). Archaeology of a Bookstack: Some Major Introductory Physics Texts of the Last 150 Years. *Physics Today*, 52, 3.

Jobrack, Beverlee. *Tyranny of the Textbook: An Insider Exposes How Educational Materials Undermine Reforms*. Lanham, Md: Rowman & Littlefield Publishers, 2011. Print.

National Air and Space Museum. (2002). Discovering New Planets. *The Smithsonian Institution*. Retrieved from: [http://airandspace.si.edu/etp/discovery/disc\\_planets.html](http://airandspace.si.edu/etp/discovery/disc_planets.html).

Pimentel, B. (2012, April 20). Microsoft seen betting big with Windows 8 . *The Wall Street Journal*.

Retrieved from: <http://online.wsj.com/article/BT-CO-20120420-712918.html>

Rensselaer Polytechnic Institute. (2005). Robert Resnick. Retrieved from:

<http://web.archive.org/web/20050301234315/http://www.rpi.edu/dept/phys/resnickbio.html>

Rensselaer Polytechnic Institute. (2005). Robert Resnick Faculty Profile. Retrieved from:

<http://www.rpi.edu/dept/phys/faculty/profiles/resnick.html>

Resnick, R. (1999). So you want to write a textbook? [speech recording]. Retrieved from:

<http://www.youtube.com/watch?v=THPGQDLdeHw>

Ross, A. S. (2011). Borders to shut down remaining 399 stores. *The San Francisco Chronicle*. Retrieved

from: <http://www.sfgate.com/cgi-bin/article.cgi?f=/c/a/2011/07/18/BUKT1KBRGO.DTL>

Snyder, C. (2008). Open Source Textbooks Challenge a Paradigm. *Wired Epicenter*. Retrieved from:

<http://www.wired.com/epicenter/2008/09/open-source-tex/>

Spector, M. & Trachtenberg, J. A. (2011). Borders, 2nd Largest Chain Bookstore, Forced to Close All

Stores. *Wall Street Journal*. Retrieved from: <http://www.infowars.com/borders-2nd-largest-chain-bookstore-forced-to-close-all-stores/>

Trachtenberg, J. A. (2011, October 31). Secret of Self-Publishing: Success. *The Wall Street Journal*.

Retrieved from:

<http://online.wsj.com/article/SB10001424052970203554104577002230413747366.html>

Victor, B. (2011, May 20). Interactive Exploration of a Dynamical System. *Worry Dream*. Retrieved from:

<http://worrydream.com/killmath>



White, M. (2003, May 13). Lexical Accessibility (LEX) – Readme. *Cornell University Computing*. Retrieved from: <http://www.soc.cornell.edu/hayes-lexical-analysis/readme13may2003.html>

Zyto, S., Karger, D., Ackerman, M. S. and Mahajan, S. (2012). Successful classroom deployment of a social document annotation system. Proceedings of the 2012 ACM annual conference / Human Factors in Computing Systems (CHI '12). ACM.